



**ISO/IEC JTC 1/SC 25/WG 1  
Interconnection of Information Technology Equipment  
Home Electronic System**

**Title:** DTR 14543-3: Information technology - Home Electronic System (HES) architecture - Part 3: Communication layers

**Source:** ISO/IEC JTC 1/SC 25/WG 1

**Project:** Project: 25.01.04.01-02: HES Architecture, Part 3

**Status:** Draft Technical Report Type 2

**Requested Action:** Approval as a Technical Report Type 2

**Distribution:** SC 25

**Draft Technical Report, Type 2**

**DTR 14543-3: Information technology  
Home Electronic System (HES)  
Architecture - Part 3: Communication  
layers**

## Contents

Foreword	iii
Introduction	iii
1 Scope	1
2 References	1
3 Definitions	1
3.1 Basic reference model definitions	1
3.2 Definitions from ISO/IEC 2382-25:1992	2
3.3 Definitions from ISO/IEC 2382-26:1992	2
3.4 Definitions from the HES Terminology	2
4 HES Reference Model	2
4.1 General	2
4.2 HES Communication model	4
4.2.1 Physical Layer	5
4.2.2 Data Link Layer	5
4.2.3 Network Layer	6
4.2.4 Transport Layer	6
4.2.5 Session Layer	6
4.2.6 Presentation Layer	6
4.2.7 Application Layer	6
4.3 HES Application model	7
4.4 HES Management model	10
4.4.1 HES system management	11
4.4.2 HES application management	13
5 Classes	15

## **Foreword**

ISO (the International Organisation for Standards) and the IEC (the International Electrotechnical Commission) form the specialised system for world-wide standardisation. National bodies that are members of ISO or IEC participate in the development of International Standards through technical committees established by the respective organisation to deal with particular fields of technical activity. ISO and IEC technical committees collaborate in fields of mutual interest. Other international organisations, governmental and non-governmental, in liaison with ISO and IEC, also take part in the work.

This Technical Report was prepared by ISO/IEC JTC1 SC25.

## **Introduction**

This Technical Report describes the architecture for the Home Electronic System.

This Technical Report on Communication Layers discusses the communication and interoperability aspects of HES. It uses the OSI model, or more precisely: the layering principles borrowed from OSI. Hence the HES-Reference Model defines the modular (layered) structure of the HES communication protocol.

The concept of Functional Groupings (FG) and Reference Points (RP) provides a means to model device modularity, and hence provides a basis for device interface standards. This is dealt with in the companion document on Device Modularity.

# Home Electronic System, HES

## Architecture

### Part 3: Communication Layers

#### 1 Scope

This Technical Report discusses the architecture of a standardised home control system, called the Home Electronic System, HES.

The detailed issues of addressing and application protocols for the Home Electronic System of different classes will be given in related standards.

#### 2 References

ISO/IEC 7498-1:1994, Information technology -- Open Systems Interconnection -- Basic Reference Model: The Basic Model

ISO 7498-2:1989, Information processing systems -- Open Systems Interconnection -- Basic Reference Model -- Part 2: Security Architecture

ISO/IEC 7498-3:1997, Information technology -- Open Systems Interconnection -- Basic Reference Model: Naming and addressing

ISO/IEC 7498-4:1989, Information processing systems -- Open Systems Interconnection -- Basic Reference Model -- Part 4: Management framework

ISO/IEC 2382-25:1992, Information technology - Vocabulary - Part 25: Local Area Networks

ISO/IEC 2382-26:1993, Information technology - Vocabulary - Part 26: Open Systems Interconnection

#### 3 Definitions

For the purpose of this Technical Report, the following definitions apply.

##### 3.1 Basic reference model definitions

This Technical Report makes use of the following terms defined in ISO/IEC 7498-1:

(N)-entity  
(N)-service-data-unit  
(N)-protocol-data-unit  
application-entity  
application-process  
connection-mode transmission  
connectionless-mode transmission  
segmenting

reassembling

### **3.2 Definitions from ISO/IEC 2382-25:1992**

This Technical Report makes use of the following terms defined in ISO/IEC 2382-25:

bridge  
repeater

### **3.3 Definitions from ISO/IEC 2382-26:1992**

This Technical Report makes use of the following term defined in ISO/IEC 2382-26:

application service element

### **3.4 Definitions from the HES Terminology**

This Technical Report makes use of terms defined in “Information Technology - Home Electronic System (HES) - Part 1 - Terminology for HES” as defined in ISO/IEC TR 15044: Information technology - Terminology for Home Electronic System (HES).

## **4 HES Reference Model**

### **4.1 General**

The HES model is based on the OSI Reference Model. Because the requirements of HES are more specific than those of OSI, and also for reasons of protocol efficiency, some of the layers of the OSI Reference Model are null or have reduced functionality in the HES Reference Model. In particular, some implementations have little or no functionality at one or more of the layers: transport, session and presentation. If a layer has no functionality of its own, then it is still regarded as present, merely to map between the layer below and the layer above. Null layers impose no overhead on any implementation.

The OSI layered reference model defines a framework for functional requirements for interconnection of systems. It does explicitly not deal with: interworking (which is an application concept and hence by definition beyond the OSI domain whereas this is included in the HES Reference Model), nor with implementation, interfaces or modularity. The major concepts introduced and defined in the OSI model are layer, service, and protocol. The rich functionality of the full OSI model is not needed in the relatively simple case of home automation, therefore only a subset of the OSI model is used to construct the HES Reference Model. On the other hand the OSI model does not deal with real time signals, nor with switched circuit transmission channels as defined for HES Class 2 and 3. Therefore the OSI model needs to be extended to address HES Class 2 and 3 services. (Figure 1)

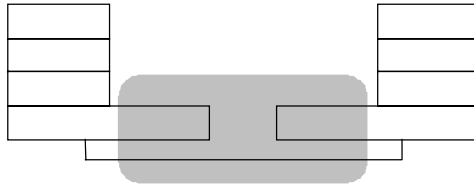

Figure 1 - Real time signals, switched channel domain

This method to construct the HES reference model is purely communication oriented. Since HES Reference Model also addresses network management and distributed processing in the application domain, it is also interoperability oriented.

Figure 2 depicts the overall structure of the HES Reference Model. An HES implementation consists of a control channel and optionally one or more information channels. Note that the control channel and information channel or channels may be on the same or different media (which may be of different types).

As shown in Figure 2 the HES Reference Model consists of three parts:

- communication model
- application model
- management model

These are defined in the following sections.

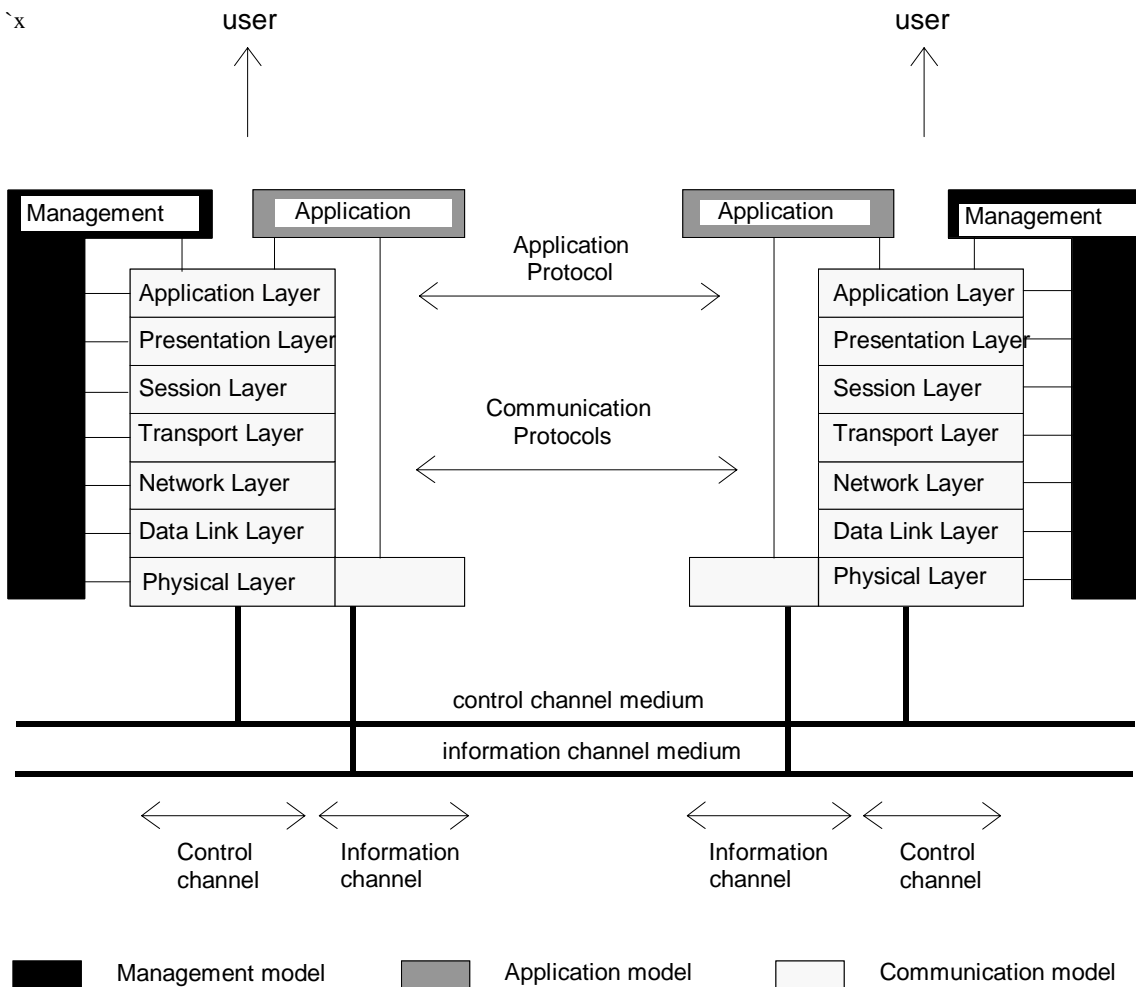

Figure 2 - Overview of the Home Electronic System Reference Model

#### 4.2 HES Communication model

In the HES Reference Model a distinction is made between information and control channels. The control channel uses packet-switched transmission, whereas the information channel typically uses circuit-switched transmission.

Packet-switched transmission is fundamental to the Home Electronic System, and all HES implementations shall provide a packet-switched control channel.

The layers of the control channel correspond to the OSI Reference Model.

This Technical Report does not describe layers below the Network Layer. However, the HES can accommodate multiple transmission media. Since different transmission media have different characteristics, the Physical Layer and Data Link Layer services can be distinct or optimised for different media. Above the Data Link Layer the services provided are medium independent. The

performance characteristics may differ according to the medium used. For instance, the potential transfer capacity of power line may be less than that of twisted pair.

Clause 4.2 gives an overview of the functions of each layer of the control channel. Other parts of this Technical Report will discuss the layers in more detail. Each layer offers services to the layer immediately above. (The Application Layer provides services to an application in a device).

#### **4.2.1 Physical Layer**

A detailed discussion of the Physical Layer is not a part of this report, however a brief overview is included below.

The Physical Layer provides mechanical, electrical, functional and procedural means for communication between data-link entities. A physical connection may involve intermediate physical repeaters, each relaying bit transmission within the Physical Layer. Physical Layer entities are interconnected by means of a physical medium.

The Physical Layer may offer two types of communication service. The control channel uses packet-switched transmission. Information channels typically use circuit-switched transmission. Every information channel shall have an associated control channel to manage it (though the same control channel may manage several information channels).

The transmission media may also provide power distribution services.

#### **4.2.2 Data Link Layer**

A detailed discussion of the Data Link Layer is not a part of this report, however a brief overview is included below.

The Data Link Layer provides

- procedural means for connectionless-mode transmission between network entities
- transfer of information between network entities
- (optionally) establishment, maintenance and release of data link connections between network entities.

A data link connection is built upon one or more physical connections.

The Data Link Layer detects errors and may offer error correction capability. Uncorrected errors may be reported to the Network Layer. The Data Link Layer provides the means to access the medium, handling contention for access when necessary.

The Data Link Layer may also implement flow control in order to manage the rate of information transfer and sequence numbering to manage the ordering of data link service data units.

The Data Link Layer shall provide recognition of data link addresses, and may provide to the Network Layer confirmation of the success or otherwise of services requested by the Network Layer.

A Data Link Layer implementation may make use of bridges to link transparently several data links in series to provide a data link service.

### **4.2.3 Network Layer**

The Network Layer services provide the procedural means for connectionless-mode or connection-mode transmission between transport entities and, therefore, provides to the transport-entities independence of the route and topology of the network segment. This includes the case where several network segments are used in series or in parallel. It makes it invisible to transport-entities how underlying resources such as data link connections are used to provide network services. Network Layer services may provide notification to the Transport Layer of errors which have been reported by the Data Link Layer, and also of errors in protocol procedure which may occur in implementing the Network Layer services.

Network Layer services may also implement flow control to manage the rate of information transfer and sequence numbering to manage the ordering of network service data units.

Network Layer services shall provide recognition of network addresses, and may provide to the Transport Layer confirmation of the success or otherwise of services requested by the Transport Layer.

In some implementations the Network Layer may have null functionality.

### **4.2.4 Transport Layer**

The Transport Layer provides transparent transfer of data between session-entities and relieves them from any concern over the detailed way in which reliable transfer of data is achieved.

All protocols defined in the Transport Layer have end-to-end significance, they are carried transparently across the network.

There are in principle two purposes of the HES Transport Layer:

- to provide a transport service using connection-mode transmission over the connectionless network service.
- to provide data segmenting/reassembling

These services are in addition to a connectionless service with no segmentation: this capability is assumed to be provided in all cases.

In some implementations the Transport Layer may have null functionality.

### **4.2.5 Session Layer**

No functionality has been defined for the Session Layer within HES at present.

### **4.2.6 Presentation Layer**

No functionality has been defined for the Presentation Layer within HES at present.

### **4.2.7 Application Layer**

The Application Layer provides a means for the device application-processes to access the HES communication resources. Each device application-process is represented to its peer by the application-entity. The application-entity contains one user element and a set of application-service-elements. The application service elements may call on the presentation services to perform their function.

### 4.3 HES Application model

One of the main characteristics of an HES is that most of its application-processes are distributed. This is illustrated in Figure 3, which shows only one application-process for simplicity. A device may belong to more than one application-process.

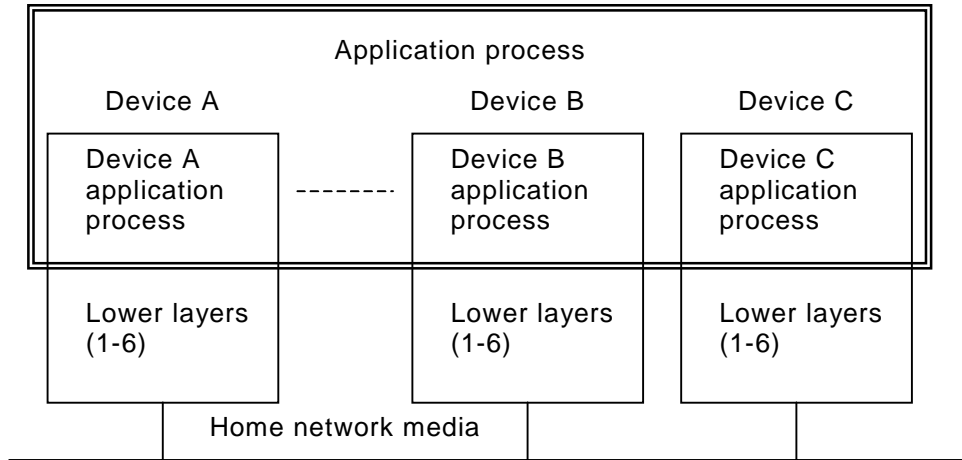

Figure 3 - Application-process of an HES

How the application-process is structured is shown in Figure 4. It consists of the device application-process and an optional local application-process. An application-process performs information processing and communications by executing programs and user instructions. That part of the application-process concerned with communications is called the application-entity. The application-entity is composed of a user element and application service elements.

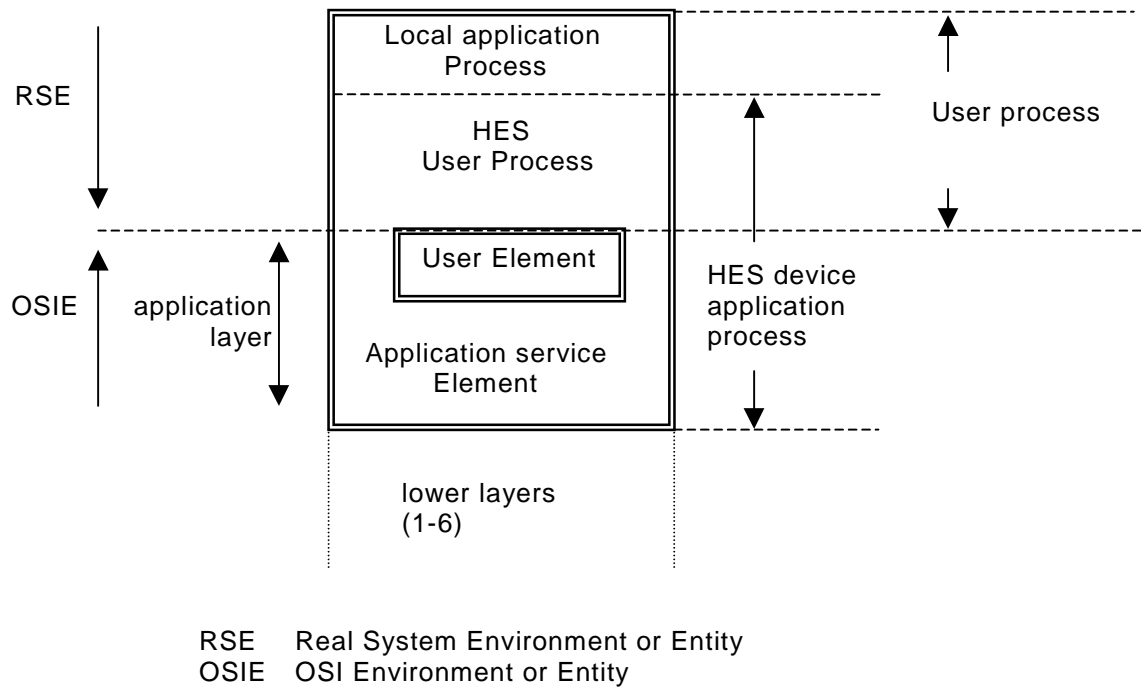

Figure 4 - HES Device Application Process

As shown in Figure 5 the device application-process is composed of application objects.

Application objects located within the user element are called communication objects. The user element and the associated application service elements (ASE) allow the user process to communicate via the HES communication system (Figure 6). A user process may use more than one application service element for this communication.

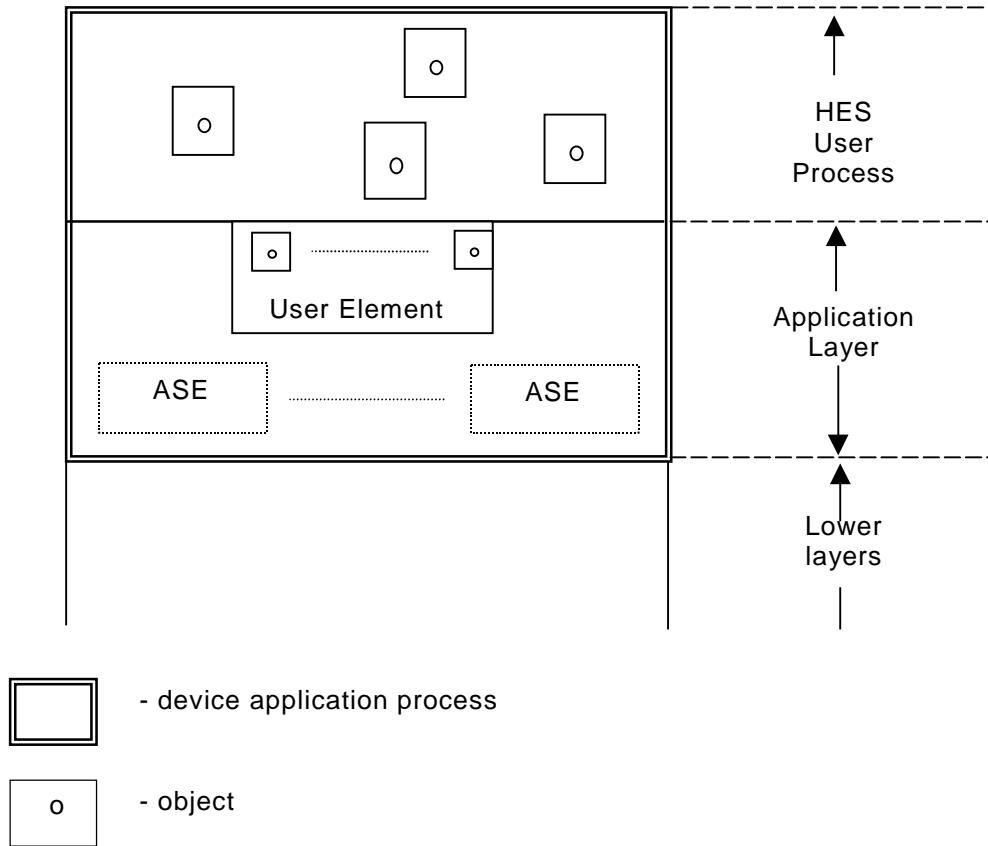

Figure 5 - Device application-process model

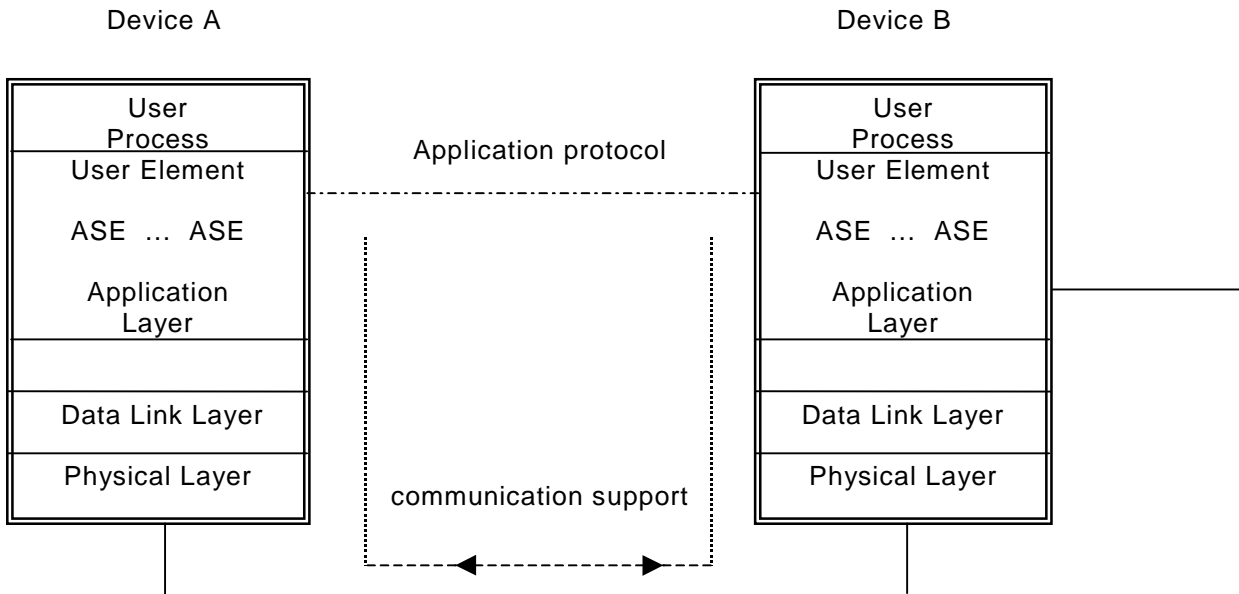

Figure 6 - Link of user processes

#### 4.4 HES Management model

The management aspects of the HES concern the problems of initiating, testing, terminating, and monitoring the HES activities and assisting in their normal operations, as well as handling abnormal conditions.

Typical management activities are:

- a) activation/deactivation:  
activation, maintenance and termination  
parameter initialisation and modification
- b) monitoring:  
status and status change registration and reporting  
statistics registration and reporting
- c) error control:  
error detection  
diagnostic functions  
reconfiguration and restart

From a functional point of view the management aspects of the HES can be divided into two main parts:

- a) System management, which deals with management of communication resources.
- b) Application management, which deals with management of application-processes.

#### 4.4.1 HES system management

The system management entity (SME) is in charge of the management of communication resources. Inside this system management, layer management entities (LMEs) interface to each layer.

Below are some examples of Layer Management functions:

- Control of N-layer operation(s) (enable/disable/reset/etc.)
- Modification of parameters general for a specific type of N-layer operation
- Registration of status of N-layer operation(s); reporting to SME
- Quality of N-layer operation(s) (number of successful transmissions per time-unit)
- N-layer operation(s) error detection to identify the demand for error control
- N-layer operation(s) error diagnostics to identify needed error control activities
- N-layer operation(s) reset

Below are some examples of General Systems Management Functions:

- Set mode of operation (normal/test/maintenance/etc.) for single device/group of devices/whole system
- Initialisation and modification of system parameters (communication relations)
- Status of single device/group of devices/whole system; remote error indication to user
- Registration and reporting of performance for single device/group of devices/whole system
- Single device/group of devices/whole system error detection to identify the demand for error control
- Single device/group of devices/whole system error diagnostics to identify needed control activities
- Single device/group of devices/whole system reset

The general structure of management of communication resources for a device is illustrated in Figure 7.

For communication to the SME in a remote device, the SME uses the services available on the layer 7 service boundary.

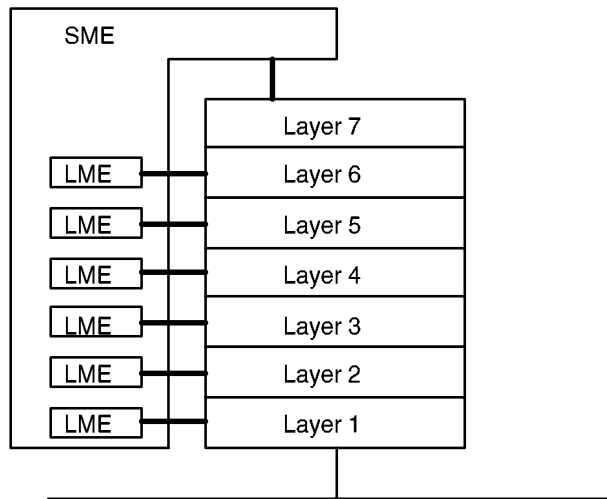

Figure 7 - Management of communication resources

The (human or user) management of the communication resources interfaces to the application-process as well as to the system management. This is illustrated in Figure 8.

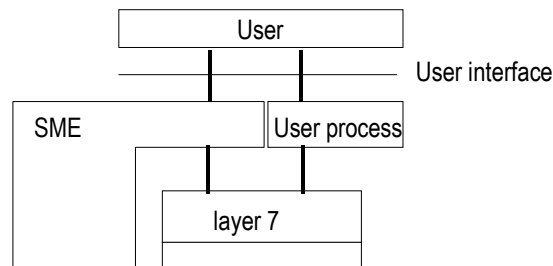

Figure 8 - User Interface of the communication resources

The management of the communication resources by the layer management entities (LMEs) is strictly a layer function which do not have direct (human) manager access.

All devices in a network must have a defined minimum functionality of the SME.

Devices may have additional management functionality to assist the human manager.

The definition of interfaces in other parts of this Technical Report allows implementations such that the lower layers are implemented in a Network Access Unit (NAU) separate from the upper layers which are implemented in the end user device. In such a case the lower layer unit must have some means for its own management, i.e. reduced functionality of the upper layers as well as reduced HES/SME functionality. Figure 9 shows the generalised case of NAU management functionality.

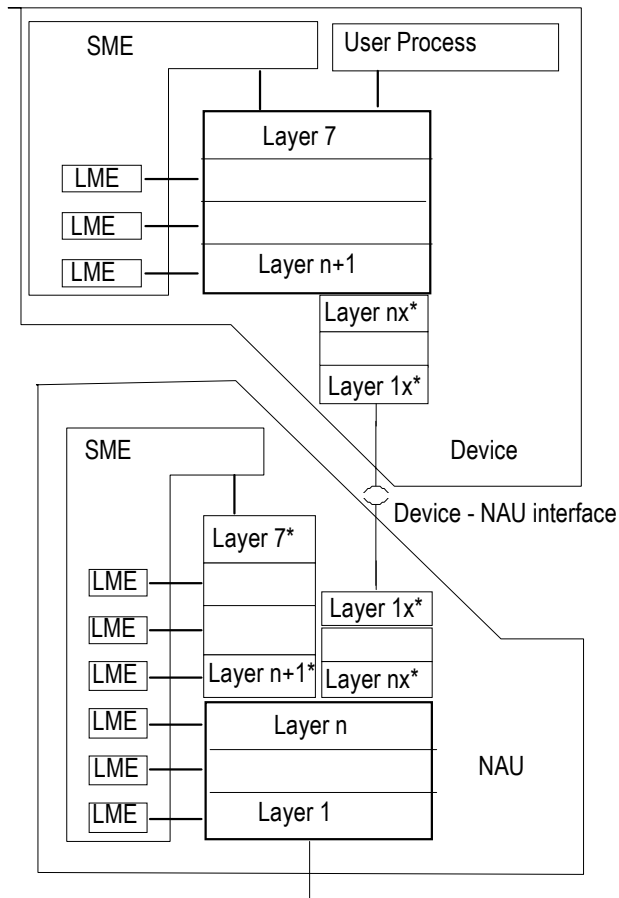

\* may be reduced in functionality.

Layers 1x to nx are the local protocol layers belonging to the interface between the NAU and the device.

Figure 9 - Management functions of NAU.

#### 4.4.2 HES application management

The management of the application-processes is responsible for managing priority conflict and synchronisation between application-processes, including proper initiating, monitoring and terminating of application-processes in remote devices. For this purpose an Application Management Entity (AME) is defined.

Below are some examples of Application Management functions.

- Control of application-process operation
- Initialisation and modification of application-process parameter(s)
- Status of application-process operation(s)
- Registration and reporting of application-process performance
- Application-process operation(s) error detection to identify the demand for error control
- Application-process operation(s) error diagnostics to identify needed control activities
- Application-process operation(s) reset

The general structure of the management of application-processes is illustrated in Figure 10. The application-process in an HES may use the control channel as well as one or more information channels.

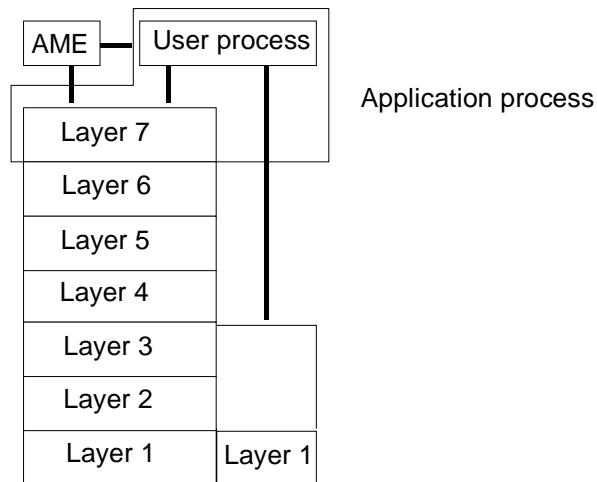

Figure 10 - Application Management

The (human or user) management of the application-process resources as well as the application-process itself interface to the user. This is illustrated in Figure 11.

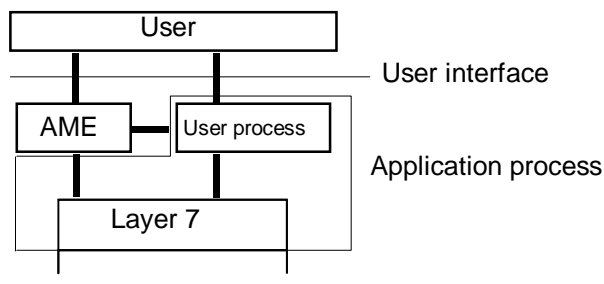

Figure 11 - User Interface to the application process resources

All devices in a network must have defined minimum functionality of the AME.

Devices may have additional management functionality to assist the human manager.

## **5 Classes**

The three classes of home control systems are defined in ISO/IEC TR 15044: Information technology - Terminology for Home Electronic System (HES).

Class 2 may be interpreted as an extension or a superset of Class 1 in that it has narrow bandwidth switched channels that do not exist in Class 1 system definition

Similarly Class 3 may be interpreted as an extension or a superset of Class 2 in that it provides switched high bandwidth channels beyond the requirements for a class 2 system.

The control channel covers the requirements for all these classes.

For Class 2 and 3 systems, the control channel, and Class 2 and 3 information channels may exist on the same or different media in any combination. Some examples are shown in Figure 12.

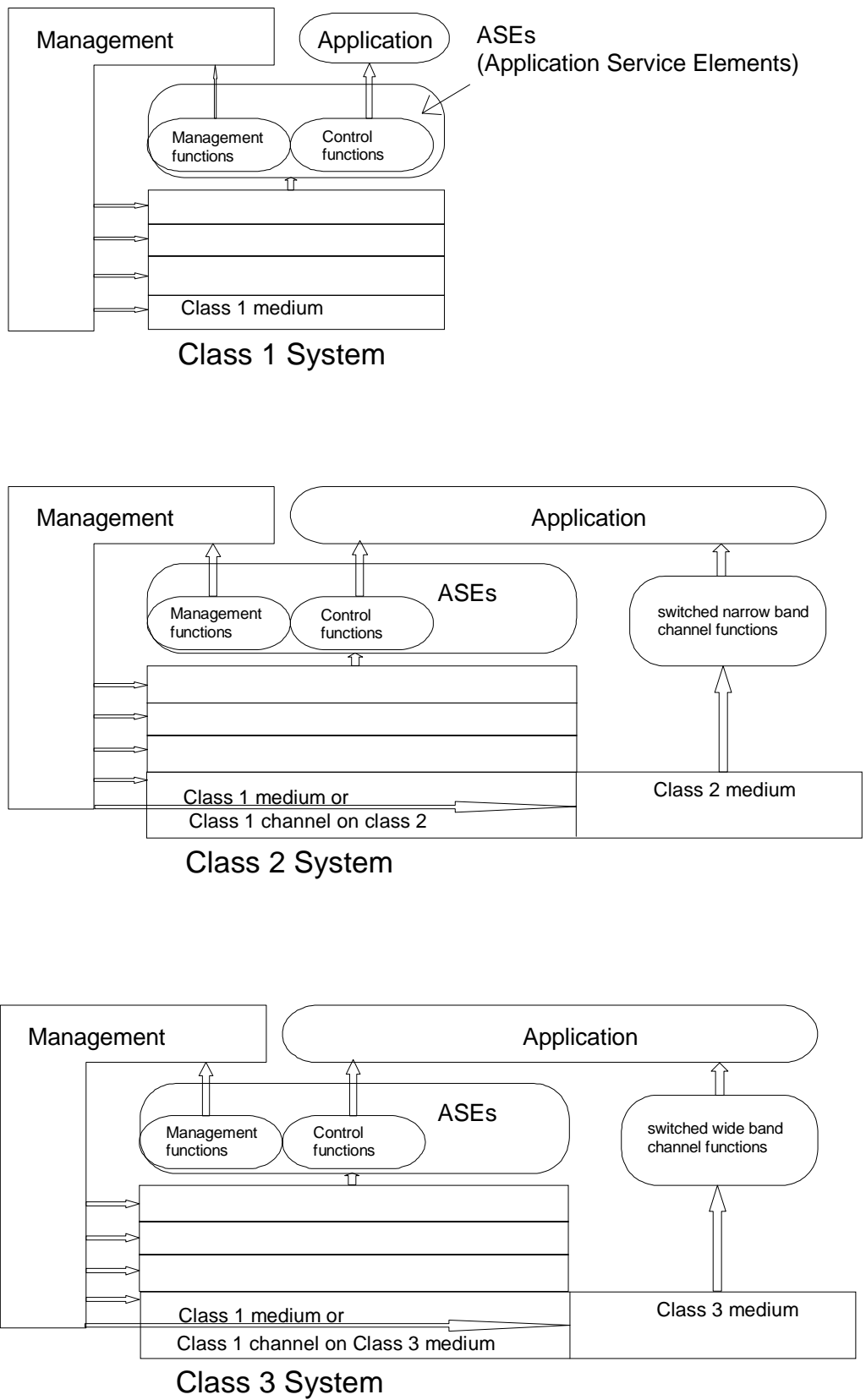

Figure 12 - Examples of Class 1, 2 and 3 HES